



A SOLUTION FOR MAKING ALL PREMISES ACCESSIBLE

KONE Motala™ 2000

IMPROVED ACCESSIBILITY

A lift in a multi-storey building is a convenience for anyone, but for many people it is a necessity. The elderly, people with disabilities, and parents with small children in strollers may find it difficult or impossible to climb stairs.



In many two or three storey buildings, such as private homes, small apartment buildings or public buildings such as libraries, a full-size lift is not a practical solution. It would cost too much and take up too much space.

The KONE Motala™ 2000 platform lift is specifically designed for these requirements. It can quickly and easily be installed and requires a small amount of space. It enables elderly people to live in their own homes longer and it ensures that public buildings and business owners meet their requirement to provide equal access for all.

KEY ADVANTAGES AND BENEFITS

- Very space-efficient: most platform space for shaft dimensions
- Easy and safe to use
- Quiet and comfortable
- Self-supporting construction, no machine room required
- Fast installation
- Extremely reliable, high-quality construction
- Different design options available to suit any building
- Low 0.75 kW power consumption
- Voice communication with 24-hour KONE Customer Service Centre
- Five-year warranty on motor and gearbox
- Ten-year warranty on patented chain guide system

SAFE AND EASY TO USE

The heart of the KONE Motala 2000 platform lift is a patented guided chain drive system. The chain is enclosed in a track along its entire length, so it can never derail. The inverter drive ensures smooth starting and stopping. Thanks to the large “hold to run” pushbuttons, the KONE Motala 2000 is easy to use.

QUICK TO INSTALL

Due to its small space requirements, with no machine room, the KONE Motala 2000 is quick and easy to install. The lift can usually be installed in a two-storey building in just a few days.

ECO-EFFICIENT

Thanks to its low power consumption, small fuse requirements, and low maintenance needs, the KONE Motala 2000 is economical to use. This solution uses less energy than a standard platform lift. With LED lights and automatic switching off of internal lighting when the lift is not in use, consumption is reduced still further. The low power consumption, 0.75 kW instead of the conventional 1.1 kW, enables the use of a 10 A fuse instead of 16 A, minimising operating costs.

During installation, the gearing mechanism is greased for lifetime use. So there are no messy oil leaks, no need to change the oil, and no waste oil to dispose of.



The KONE Motala™ 2000 platform lift suits the architecture of any building, thanks to the wide range of car and shaft design options.



The compact platform lift does not require a machine room and fits easily into many buildings.

AESTHETIC SOLUTIONS FOR ANY BUILDING

Every building is different, and so is every KONE Motala™ 2000 platform lift. The Motala 2000 shaft can be glazed on all sides in order to let light in and to give the lift a more open character. There are several door choices, including fire-rated doors. For the lift car, several ceiling and flooring options are available.

DOORS

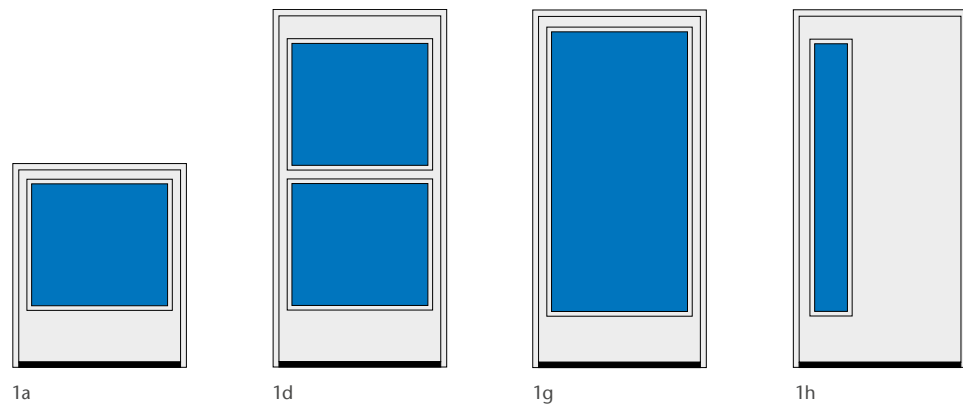

- Full or half height (2000 or 1300 mm on top floor)
- Swing door (900 x 2000 mm)
- Manual door with door closer automatic door opener (optional)
- Doors can be fitted on 3 sides
- Right or left hand opening
- Doors options 1d and 1h are available as certified fire doors (EI30).

FLOORS

VINYL



Grey (18383) Yellow (18772) Green (18780) Dark Oak (11522)



Light Granite (3116561) Dark Granite (3116568) Classic Oak (11542) Cherry (111492)

RUBBER



Grey Coin Pattern (SC009)

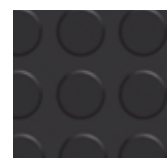

Black Coin Pattern (SC001)

PLATFORMS



Standard



Exclusive Oak



Exclusive Steel

OTHER OPTIONS

- Factory paintwork, RAL colours
- Glazed shaft
- Automatic swing doors
- Folding chair
- Handrail (standard)
- Braille signalisation (standard)
- Electrical emergency lowering (standard)
- Audible announcements (voice synthesiser)
- Extra wide doors (1000 mm)
- Landing floor buttons away from the platform lift for easier use by people in wheelchairs
- Stainless steel and/or wooden door handles
- KONE Motala Exclusive interior materials

SHAFT

The shaft glazing is available in several different shades.



Ocean 1



Ocean 2



Bronze 1



Bronze 2



Smoke 1



Smoke 2



Frosted 1



Frosted 2



Clear

CONTROL PANEL



- Large easy-to-use buttons (50 x 50 mm)
- Hold to run
- Emergency stop button

LIGHTING



- LED lights in the ceiling
- Emergency LED lighting

KEY FEATURES AND DIMENSIONS

DIMENSIONS

(mm)	MOTALA 2000 HOME	MOTALA 2000	MOTALA 2000 XL
Shaft size	1150 x 950	1150 x 1560	1150 x 1760
Platform size	1020 x 870	1020 x 1480	1020 x 1680
Shaft size	1250 x 950	1250 x 1560	1250 x 1760
Platform size	1120 x 870	1120 x 1480	1120 x 1680
Shaft size	1350 x 950	1350 x 1560	1350 x 1760
Platform size	1220 x 870	1220 x 1480	1220 x 1680

Motala 2000 Home for private homes, Motala 2000 for public buildings, Motala 2000 XL with extra large platform.



SHAFT INSTALLATION SPACE

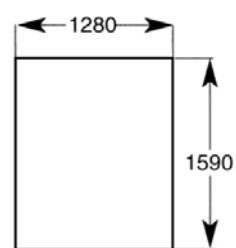

The dimensions in these pictures are for the shaft size 1250 x 1560.

SERVICE PANEL IN FRAME

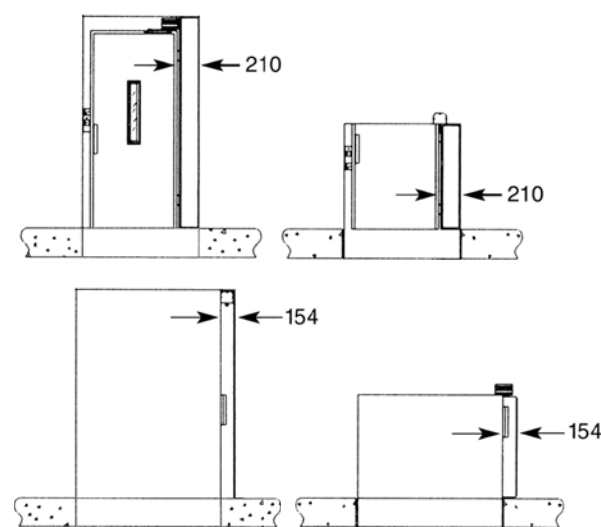

SHAFT AND PLATFORM DIMENSIONS

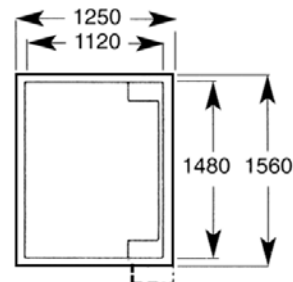

RAMP



SPECIFICATIONS

- Travel: max 15 m
- Speed: 0.15 m/s
- Stops: 2 – 6
- Pit: 60 mm depth, alternatively a ramp
- Rated load: 500 kg (400 kg for Motala 2000 Home)
- Headroom: 2230 mm
- Supply voltage: 230-240 V / 10 A
- Drive system: 0.75 kW enclosed geared motor, lifecycle greased gear
- Shaft: Self-supporting enclosure. No need for conventional shaft
- Platform: L-shaped platform with safety edge
- Emergency lowering: Manual and electric emergency lowering standard
- Alarm: Battery-powered, automatically recharging alarm system. Emergency buzzer. Optionally, two-way voice connection to 24h KONE Customer Care Centre with KONE Voice Link™
- Certificate: 85618-2010-CE-NOR-DNV
- Fulfils European Union Machinery Directive 2006/42/EC and European Harmonised Standard EN81-41

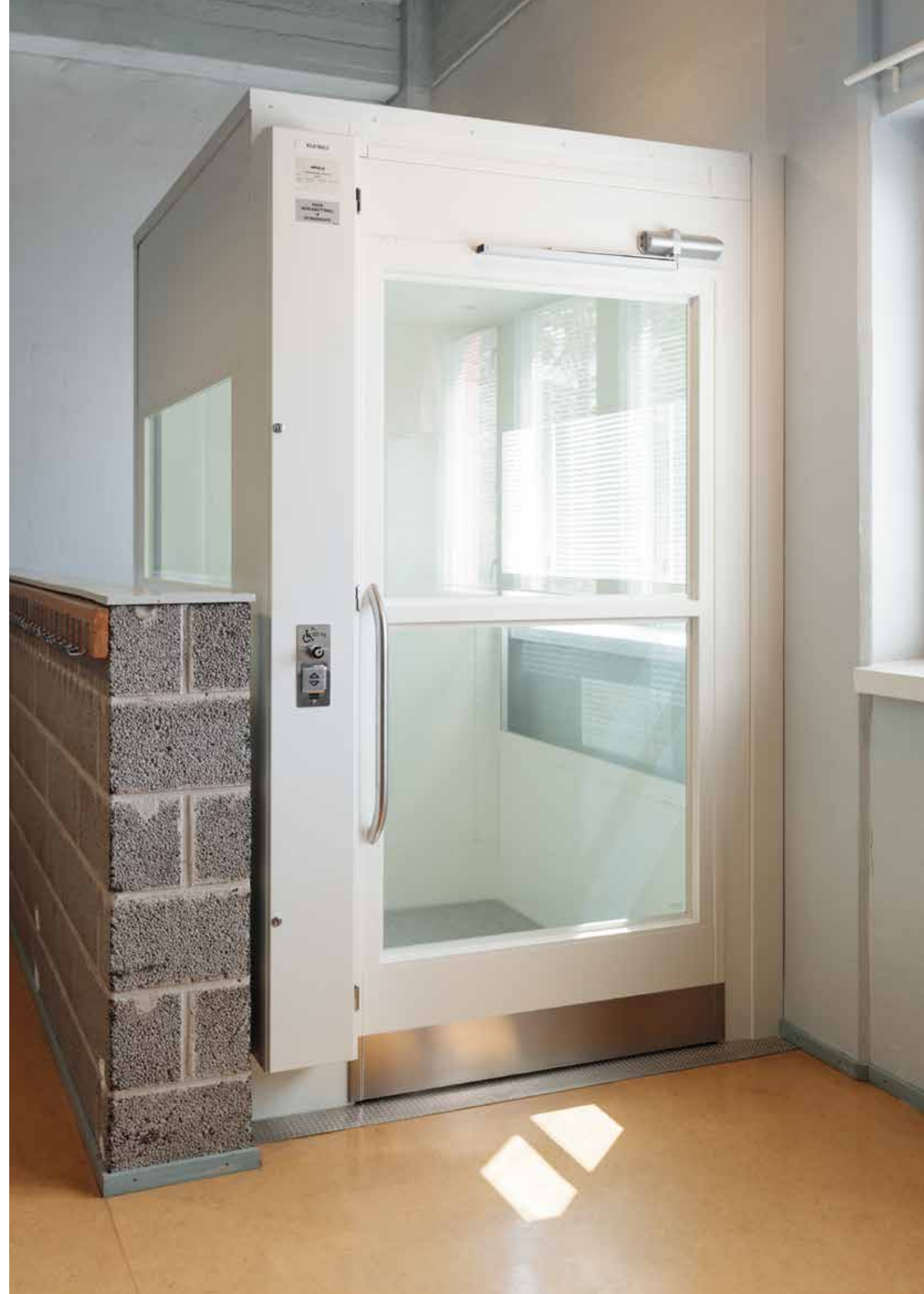

KONE provides innovative and eco-efficient solutions for elevators, escalators, automatic building doors and the systems that integrate them with today's intelligent buildings.

We support our customers every step of the way: from design, manufacturing, and installation to maintenance and modernization. KONE is a global leader in managing the smooth flow of people and goods throughout buildings.

This makes us a reliable partner throughout the life cycle of buildings. We are fast, flexible, and we have a well-deserved reputation as a technology leader, with such innovations as KONE MonoSpace®, KONE NanoSpace™, and KONE UltraRope®.

KONE employs over 55,000 dedicated experts to serve you globally and locally.

KONE PLC

Head office

KONE Plc
Global House,
Station Place, Fox Lane North
Chertsey, Surrey,
KT16 9HW

Tel. +44 (0) 8451 999 999

www.kone.co.uk

KONE IRELAND

Head office

KONE Ireland Limited
G7 Calmount Business Park
Calmount Avenue
Ballymount
Dublin D12 NP64

Dublin office: +353 (0) 1429 6200
Belfast office: +44 (0) 2890 735900

www.kone.ie